

Gummiprofile zum Einnuten Nr. 526 + 634 (Türen/Fenster)

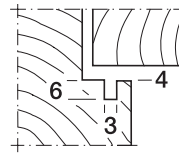

Nr. 526



HEBGO-Hohlkammerdichtung, Silikon-Qualität

Rollen à 50 m

Kleinpackungen à 7 m

526.1 schwarz
526.2 braun
526.7 grau
526.9 weiss

526.1k schwarz
526.2k braun
526.7k grau
526.9k weiss



Nr. 634



HEBGO-Lippendichtung, Silikon-Qualität

Rollen à 50 m

Kleinpackungen à 7 m

634.1 schwarz
634.2 braun
634.7 grau
634.9 weiss

634.1k schwarz
634.9k weiss

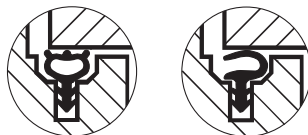
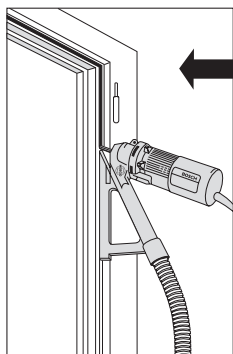
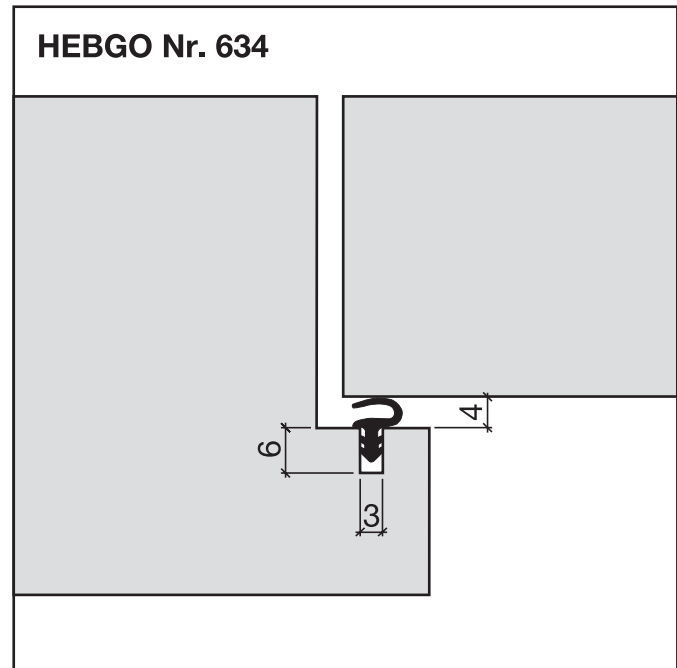
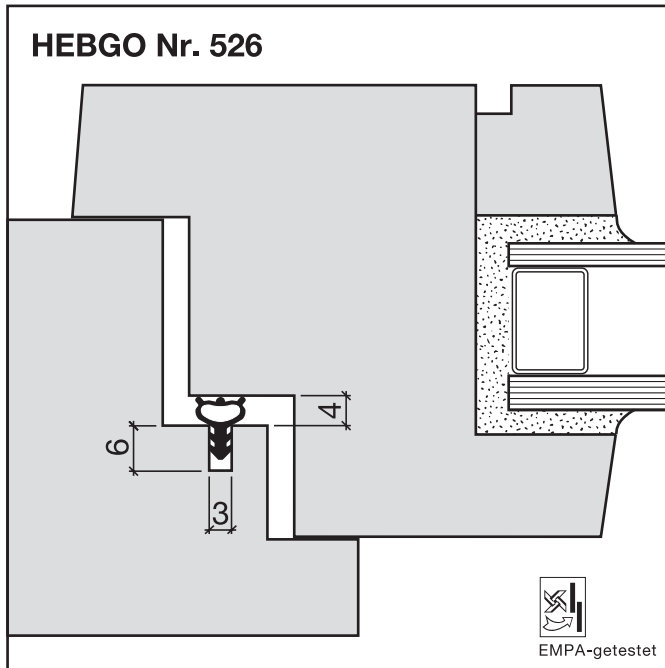

Sanierungssystem mit HEBGO-Doppelnutfräse siehe Seite H. 01

mit Maschine, Nutfräse 500W, 240V

Dichtungsprofil Nr. 126 für Metallbau (Sanierung)

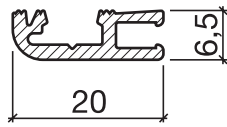

Nr. 126

HEBGO-Sanierungsprofil aus Aluminium

Lagerlänge 5250 mm (☼ = 20)

- 126.0** blank
- 126.1** farblos eloxiert
- 126.2** bronzefarbig eloxiert

HEBGO-Hohlkammerdichtung, Silikon-Qualität

Rollen à 50 m

Kleinpackungen à 7 m



Nr. 526



- | | |
|----------------------|-----------------------|
| 526.1 schwarz | 526.1k schwarz |
| 526.2 braun | 526.2k braun |
| 526.7 grau | 526.7k grau |
| 526.9 weiss | 526.9k weiss |

HEBGO-Lippendichtung, Silikon-Qualität

Rollen à 50 m

Kleinpackungen à 7 m



Nr. 634



- | | |
|----------------------|-----------------------|
| 634.1 schwarz | 634.1k schwarz |
| 634.2 braun | |
| 634.7 grau | |
| 634.9 weiss | 634.9k weiss |

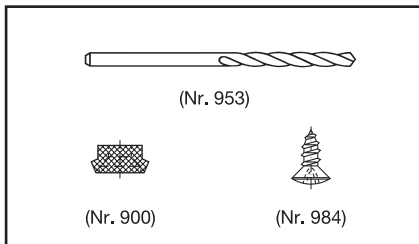

Nr. 902

HEBGO-Befestigungs-Set "Metall" (für 1 Lagerlänge)

- 902.9** 1 Tüte: 25 Delrin-Knöpfe
25 Blechschrauben, LSK, 2,9 x 6,5 mm
1 Bohrer HSS Ø 2,4 mm

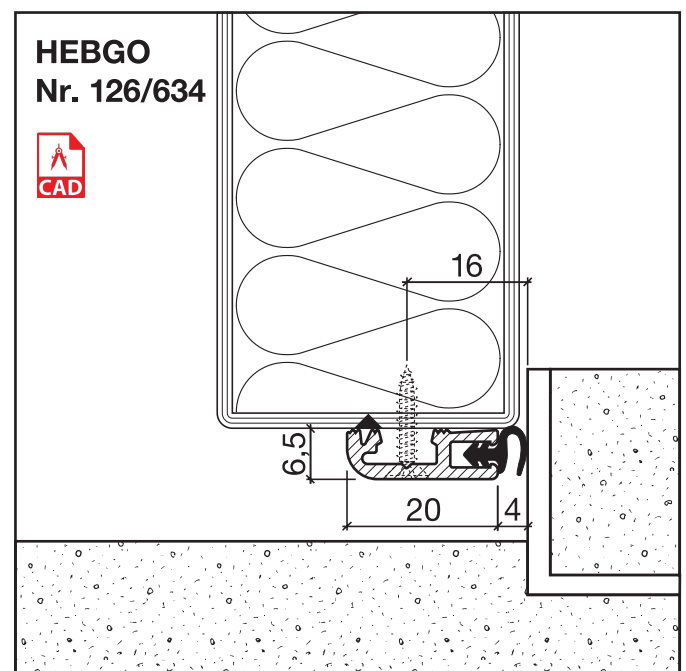
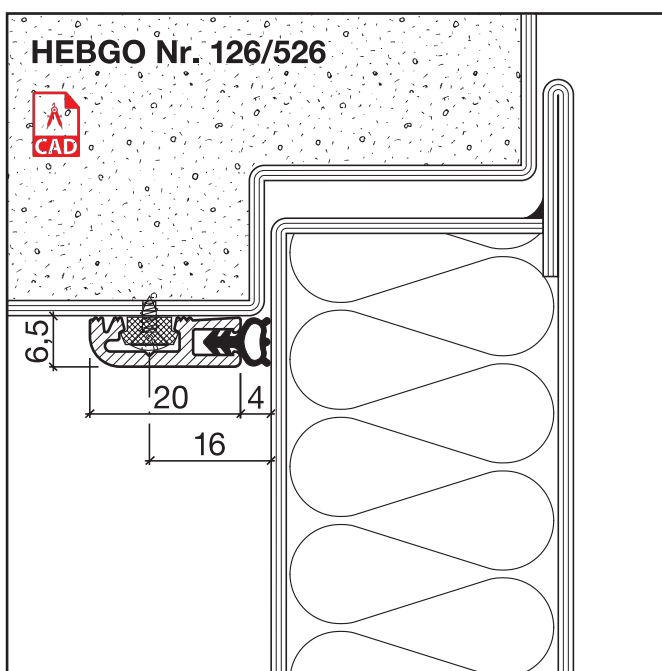

a-Wert (Luftdurchlässigkeit) siehe Seite H. 09